

B40E Articulated Dump Truck

ENGINE

Manufacturer
Mercedes Benz (MTU)

Model
OM471LA (MTU 6R 1300)

Configuration
Inline 6, turbocharged and intercooled.

Gross Power
380 kW (510 hp) @ 1 700 rpm

Net Power
359 kW (481 hp) @ 1 700 rpm

Gross Torque
2 380 Nm (1 755 lbf) @ 1 300 rpm

Displacement
12,8 litres (781 cu.in)

Auxiliary Brake
Jacobs Engine Brake®

Fuel Tank Capacity
352 litres (93 US gal)

AdBlue® Tank Capacity
40 litres (11 US gal)

Certification
OM471LA (MTU 6R 1300) meets EU Stage V emissions regulations

TRANSMISSION

Manufacturer
Allison

Model
4700 ORS

Configuration
Fully automatic planetary transmission.

Layout
Engine mounted

Gear Layout
Constant meshing planetary gears, clutch operated

Gears
7 Forward, 1 Reverse

Clutch Type
Hydraulically operated multi-disc

Control Type
Electronic

Torque Control
Hydrodynamic with lock-up in all gears.

TRANSFER CASE

Manufacturer
Kessler

Series
W2400

Layout
Remote mounted

Gear Layout
Three in-line helical gears

Output Differential
Interaxle 29/71 proportional differential. Automatic inter-axle differential lock.

AXLES

Manufacturer
Bell

Model
30T

Differential
High input controlled traction differential with spiral bevel gears

Final Drive
Outboard heavy duty planetary on all axles.

BRAKING SYSTEM

Service Brake
Dual circuit, full hydraulic actuation wet disc brakes on front and middle axles. Wet brake oil is circulated through a filtration and cooling system.

Maximum brake force:
327 kN (73 513 lbf)

Park & Emergency
Spring applied, air released driveline mounted disc.

Maximum brake force:
218 kN (49 008 lbf)

Auxiliary Brake
Automatic engine valve brake. Automatic retardation through electronic activation of wet brake system.

Total Retardation Power
Continuous: 442 kW (593 hp)
Maximum: 854 kW (1 145 hp)

WHEELS

Type
Radial Earthmover

Tyre
29.5 R 25 (875/65 R 29 optional)

FRONT SUSPENSION

Semi-independent, leading A-frame supported by hydro-pneumatic suspension struts.

Option: Electronically controlled adaptive suspension with ride height adjustment.

REAR SUSPENSION

Pivoting walking beams with laminated rubber suspension blocks.

Option: Comfort Ride suspension walking beams, with two-stage sandwich block.

HYDRAULIC SYSTEM

Full load sensing system serving the prioritized steering, body tipping and brake functions. A ground-driven, load sensing emergency steering pump is integrated into the main system.

Pump Type
Variable displacement load sensing piston

Flow
330 L/min (87 gal/min)

Pressure
315 bar (4 569 psi)

Filter
5 microns

STEERING SYSTEM

Double acting cylinders, with ground-driven emergency steering pump.

Lock to lock turns
5

Steering Angle
42°

DUMPING SYSTEM

Two double-acting, single stage, dump cylinders.

Raise Time
11 seconds

Lowering Time
6 seconds

Tipping Angle
70 deg standard, or any lower angle programmable

PNEUMATIC SYSTEM

Air drier with heater and integral unloader valve, serving park brake and auxiliary functions.

System Pressure
810 kPa (117 psi)

ELECTRICAL SYSTEM

Voltage
24 V

Battery Type
Two AGM (Absorption Glass Mat) type.

Battery Capacity
2 X 75 Ah

Alternator Rating
28V 80A

MAX. VEHICLE SPEED

1st	4 km/h	2,5 mph
2nd	9 km/h	6 mph
3rd	17 km/h	11 mph
4th	23 km/h	14 mph
5th	33 km/h	21 mph
6th	44 km/h	27,3 mph
7th	51 km/h	32 mph
R	7 km/h	4 mph

CAB

ROPS/FOPS certified 76 dBA internal sound level measured according to ISO 6396.

Load Capacity & Ground Pressure

OPERATING WEIGHTS		GROUND PRESSURE*		LOAD CAPACITY		OPTION WEIGHTS	
UNLADEN	kg (lb)	LADEN		BODY	m ³ (yd ³)		kg (lb)
Front	16 972 (37 417)	(No sinkage/Total Contact Area Method)		Struck Capacity	19 (25)	Bin liner	1 369 (3 018)
Middle	7 737 (17 057)	29.5 R 25	kPa (Psi)	SAE 2:1 Capacity	24 (31)	Tailgate	984 (2 169)
Rear	7 524 (16 588)	Front	310 (45)	SAE 1:1 Capacity	28,5 (37)	875/65 R29	
Total	32 233 (71 062)	Mid & Rear	341 (50)	SAE 2:1 Capacity with Tailgate	24,5 (32)	(per vehicle) Add	1 182 (2 606)
LADEN						EXTRA WHEELSET	
Front	21 847 (48 164)	875/65 R29	kPa (Psi)			29.5 R 25	800 (1 764)
Middle	24 800 (54 675)	Front	293 (43)	Rated Payload	39 000 kg	875/65 R29	1 024 (2 258)
Rear	24 586 (54 203)	Mid & Rear	329 (48)		(85 980 lb)		
Total	71 233 (157 042)						

* 29.5R25 Groundpressures calculated with Michelin XADN+ Tyre. 875/65R29 Groundpressures calculated with Michelin XAD65-1 Tyre.

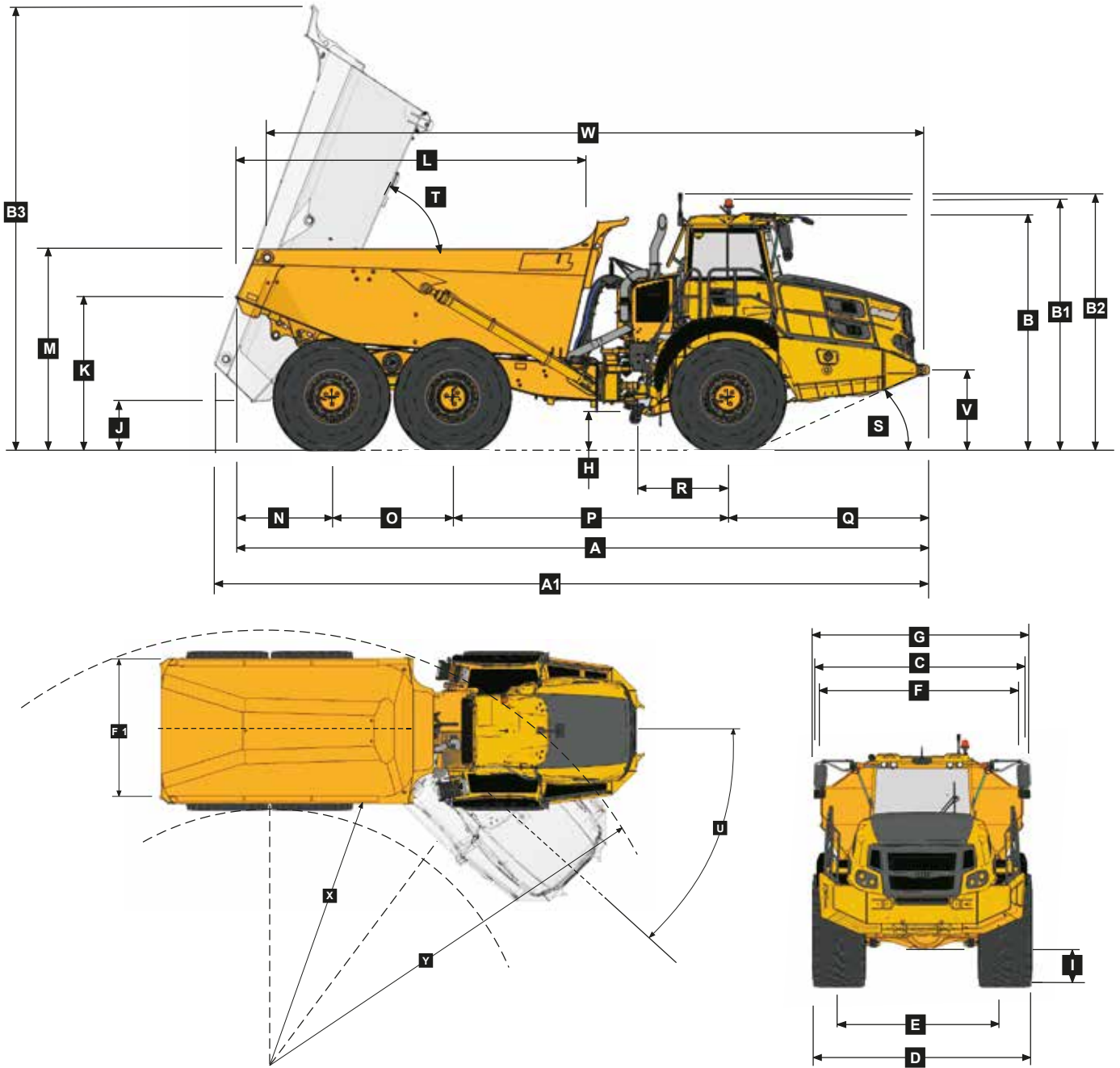

Machine Dimensions

A	Length - Transport Position with Tailgate	11 197 mm (36 ft. 9 in.)	K	Bin Lip Height - Transport Position	2 519 mm (8 ft. 3 in.)
A	Length - Transport Position w/o Tailgate	11 186 mm (36 ft. 8 in.)	L	Bin Length	5 742 mm (18 ft. 10 in.)
A1	Length - Bin Fully Tipped	11 742 mm (38 ft. 6 in.)	M	Load over Height	3 271 mm (10 ft. 9 in.)
B	Height - Transport Position	3 804 mm (12 ft. 6 in.)	N	Rear Axle Centre to Bin Rear	1 543 mm (5 ft.)
B1	Height - Rotating Beacon	4 040 mm (13 ft. 3 in.)	O	Mid Axle Centre to Rear Axle Centre	1 950 mm (6 ft. 5 in.)
B2	Height - Load Light	4 129 mm (13 ft. 7 in.)	P	Mid Axle Centre to Front Axle Centre	4 438 mm (14 ft. 7 in.)
B3	Bin Height - Fully Tipped	7 316 mm (24 ft.)	Q	Front Axle Centre to Machine Front	3 255 mm (10 ft. 8 in.)
C	Width over Mudguards	3 495 mm (11 ft. 6 in.)	R	Front Axle Centre to Artic Centre	1 558 mm (5 ft. 1 in.)
D	Width over Tyres - 875/65 R29	3 656 mm (12 ft.)	S	Approach Angle	24°
D	Width over Tyres - 29.5R25	3 487 mm (11 ft. 5 in.)	T	Maximum Bin Tip Angle	70°
E	Tyre Track Width - 875/65 R29	2 773 mm (9 ft. 1 in.)	U	Maximum Articulation Angle	42°
E	Tyre Track Width - 29.5R25	2 725 mm (8 ft. 11 in.)	V	Front Tie Down Height	1 265 mm (4 ft. 2 in.)
F	Width over Bin	3 372 mm (11 ft.)	W	Machine Lifting Centres	10 594 mm (34 ft. 9 in.)
F1	Width over Tailgate	3 662 mm (12 ft.)	X	Inner Turning Circle Radius - 875/65 R29	4 782 mm (15 ft. 8 in.)
G	Width over Mirrors - Operating Position	3 614 mm (11 ft. 10 in.)	X	Inner Turning Circle Radius - 29.5R25	4 866 mm (16 ft.)
H	Ground Clearance - Artic	545 mm (21.46 in.)	Y	Outer Turning Circle Radius - 875/65 R29	9 320 mm (30 ft. 7 in.)
I	Ground Clearance - Front Axle	545 mm (21.46 in.)	Y	Outer Turning Circle Radius - 29.5R25	9 235 mm (30 ft. 4 in.)
J	Ground Clearance - Bin Fully Tipped	876 mm (34.5 in.)			

Gradeability/Rimpull

1. Determine tractive resistance by finding intersection of vehicle mass line and grade line. NOTE: 2% typical rolling resistance is already assumed in chart and grade line.
2. From this intersection, move straight right across charts until line intersects rimpull curve.
3. Read down from this point to determine maximum speed attained at that tractive resistance.

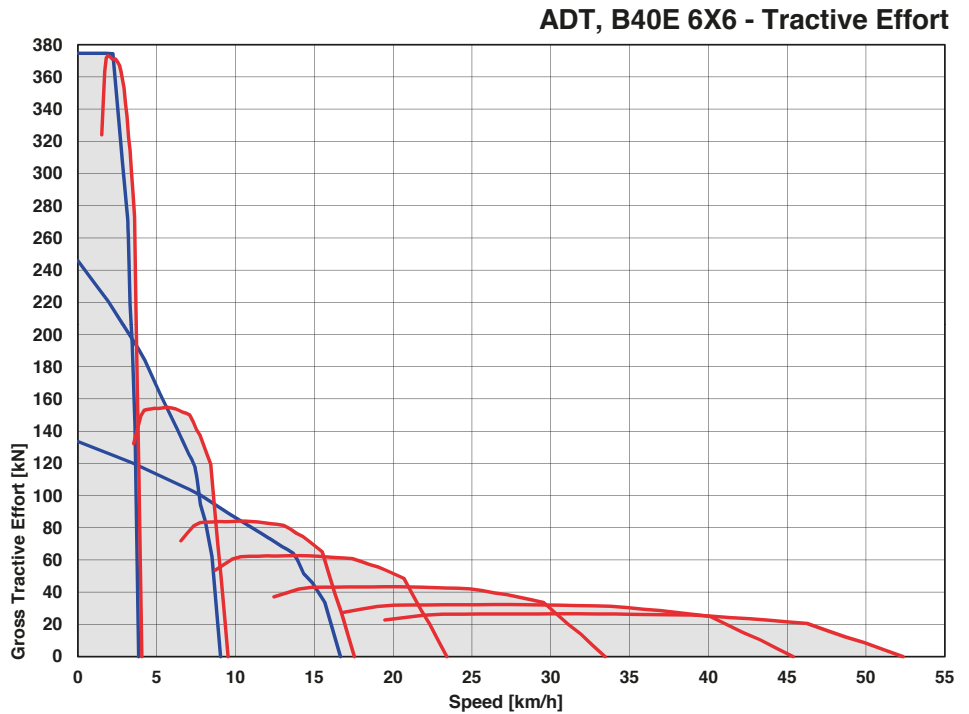
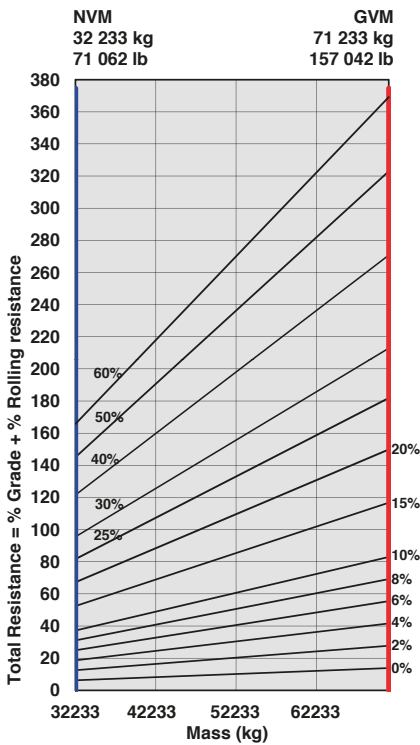

Retardation

1. Determine retardation force required by finding intersection of vehicle mass line.
2. From this intersection, move straight right across charts until line intersects the curve. NOTE: 2% typical rolling resistance is already assumed in chart.
3. Read down from this point to determine maximum speed.

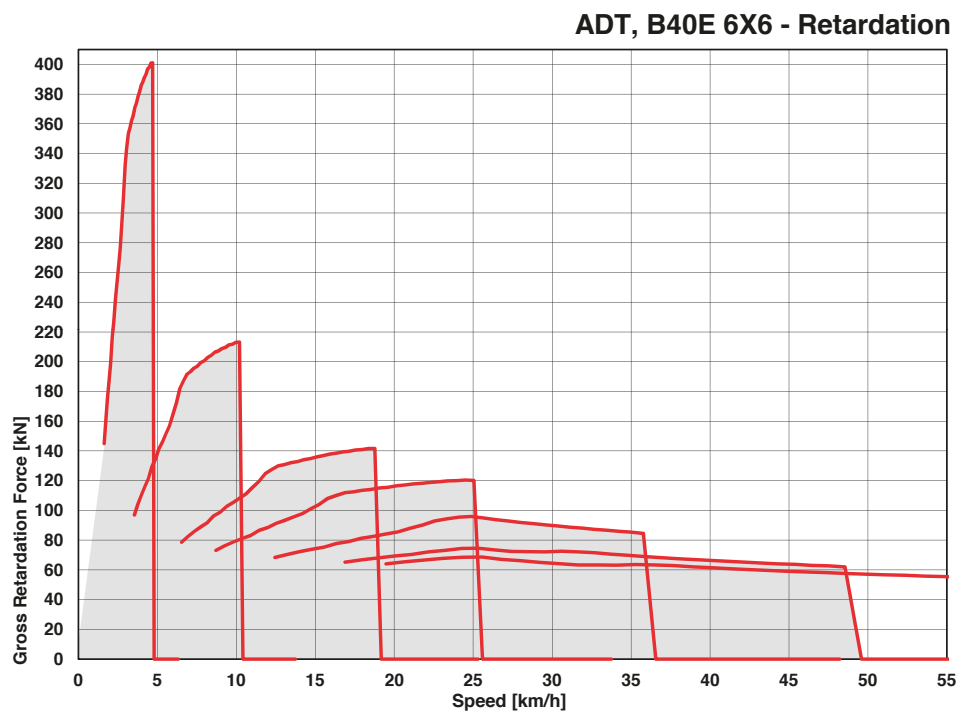
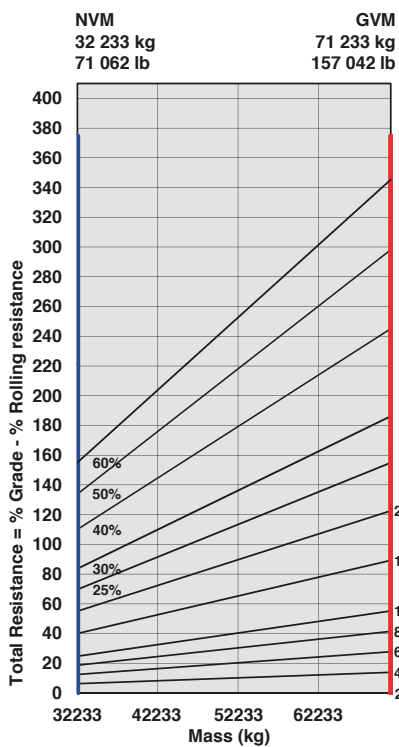

B35E	B40E	B45E	B50E		B35E	B40E	B45E	B50E					
				ENGINE					CAB (continued)				
●	●	●	●	Engine valve brake					Manually adjusted mirrors				
●	●	●	●	Dual element air cleaner with dust ejector valve					Heated mirrors				
●	●	●	●	Precleaner with automatic dust scavenging	●	●	●	●	Electrically adjusted and heated mirrors				
●	●	●	●	Water separator	●	●	●	●	Deluxe 10" colour LCD:				
●	●	●	●	Serpentine drive belt with automatic tensioner					Speedometer / Fuel gauge /				
●	●	●	●	Provision for fast fill					Transmission oil temperature gauge /				
●	●	●	●	Wet-sleeve cylinder liners					Engine coolant temperature gauge /				
				COOLING					DUMP BODY				
●	●	●	●	Crankshaft mounted electronically controlled viscous fan drive					●	●	●	●	Dump body mechanical locks (x2). Partially up and fully up
●	●	●	●	Fan guard					▲	▲	▲	▲	Body liner
				PNEUMATIC SYSTEM					OTHER				
●	●	●	●	Engine-mounted compressor	●	●	●	●	Backlit sealed switch module functions with:				
●	●	●	●	Air drier with heater					Wiper control / Lights / Heated mirrors /				
●	●	●	●	Integral unloader valve					Retarding aggressiveness / Transfer case differential lock / Transmission gear hold /				
				ELECTRICAL SYSTEM					Dump-body tip limit / Automatic dump-body tip settings / Airconditioner/ Heater controls / Preselected Speed Control				
●	●	●	●	Battery disconnect					●	●	●	●	Dump body mechanical locks (x2). Partially up and fully up
●	●	●	●	Halogen drive lights					▲	▲	▲	▲	Body liner
▲	▲	▲	▲	LED drive lights					▲	▲	▲	▲	Tailgate
●	●	●	●	Air horn					▲	▲	▲	▲	Body heater
●	●	●	●	Reverse alarm					▲	▲	▲	▲	Less dump body and cylinders
▲	▲	▲	▲	White noise reverse alarm					▲	▲	▲	▲	Low SG bin extensions
●	●	●	●	Rotating beacon					▲	▲	▲	▲	Bin pole lockout
●	●	●	●	Pitch Roll Sensor									
●	●	●	●	Halogen Artic reverse light									
▲	▲	▲	▲	LED Artic reverse light									
●	●	●	●	LED reverse lights									
				STEERING SYSTEM									
●	●	●	●	Bi-directional ground-driven secondary steering pump									
				CAB									
●	●	●	●	ROPS/FOPS certification					●	●	●	●	Automatic Traction Control (ATC)
●	●	●	●	Tilt cab					●	●	●	●	Wet disc brakes
●	●	●	●	Gas strut-supported door					●				26.5 R 25 Radial Earthmover tyres
●	●	●	●	I-Tip programmable dump-body tip settings						●	●	▲	29.5 R 25 Radial Earthmover tyres
●	●	●	●	HVAC Climate control system						▲	▲	●	875/65 R 29 Radial Earthmover tyres
●	●	●	●	AM/FM radio with Aux + USB					●	●	●	●	Remote grease banks
●	●	●	●	Rear window guard					▲	▲	▲	●	Automatic greasing
●	●	●	●	Wiper/washer with intermittent control					●	●	●	●	Onboard weighing
●	●	●	●	Tilt and telescoping steering wheel					▲	▲	▲	▲	Load lights: stack
●	●	●	●	Centre-mount air-suspension seat					▲	▲	▲	●	Comfort ride suspension (Front)
●	●	●	●	Halogen work lights					●	●	●	▲	Comfort ride suspension (Rear)
▲	▲	▲	▲	LED work lights					●	●	●	●	Reverse camera
▲	▲	▲	▲	Rotating beacon: seat belt installation					●	●	●	●	Hand rails
▲	▲	▲	▲	Remote engine and machine isolation					●	●	●	●	Cab peak
●	●	●	●	Remote battery jump start					▲	▲	▲	▲	High pressure hydraulic filter
●	●	●	●	Retractable 3 point seat belt					▲	▲	▲	▲	Fuel heater
●	●	●	●	Heated seat					●	●	●	●	Belly cover
●	●	●	●	Foldaway trainer seat with retractable seat belt					▲	▲	▲	▲	Remote transmission filters
●	●	●	●	12-volt power outlet					●	●	●	●	Engine and transmission remote drain-gravity
●	●	●	●	Cab utility bin (removable)					▲	▲	▲	▲	Engine and transmission remote drain-scavenge
●	●	●	●	Cup holder					▲	▲	▲	▲	Window smash button
●	●	●	●	Cooled/heated lunch box					●	●	●	●	High visibility mirrors
									●	●	●	●	Fleetm@tic® Classic Package for 2 years
									●	●	●	●	Electronic bonnet opening